

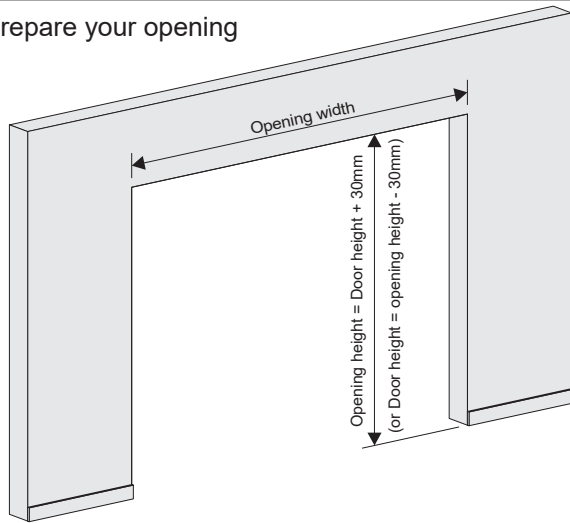

# ROBEMAKER

SLIDING WARDROBE DOOR TRACK SYSTEM - 50kg MAXIMUM DOOR LOAD

## 1. Prepare your opening



Ensure fixing surfaces are flat and solid enough to support the weight of the doors and tracks. Do not fix directly onto carpet. Do not have joins in tracks.

## 2. Fix your tracks

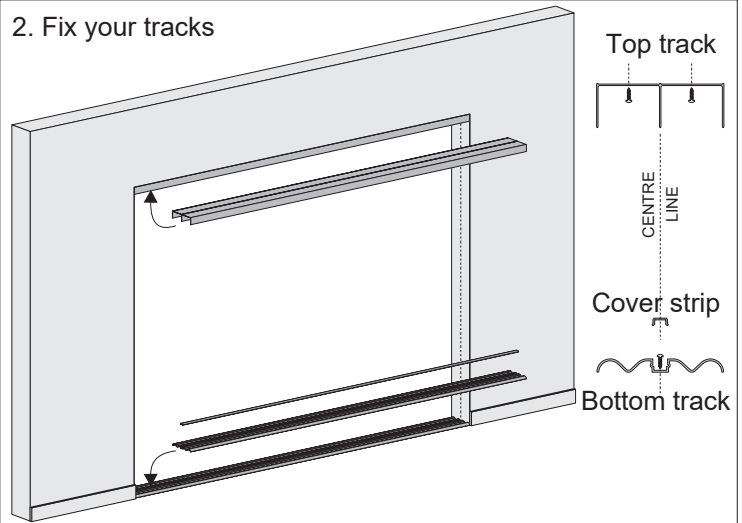

Fix the top track into the desired position and then align and fix the bottom track, centred to the top track. Finish by clipping the cover strip into place on the bottom track.

## 3. Prepare your doors

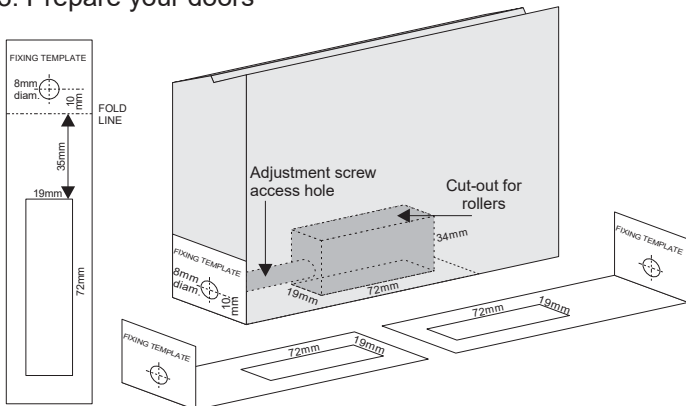

Using the fixing template, follow the guides to drill access hole and create cut-out for rollers (each end)

## 4. Fit your rollers

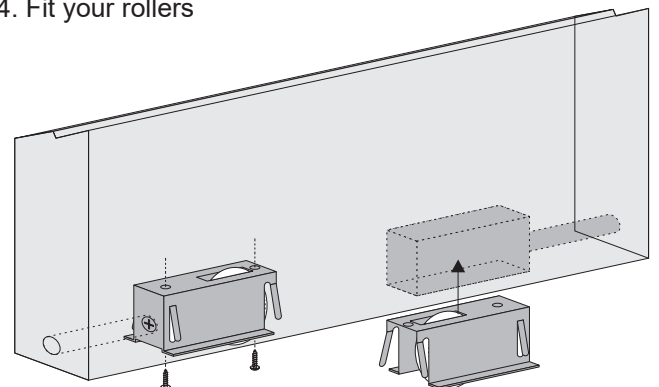

Fit rollers into the cut-outs with the adjustment screw facing the access hole. Ensure adjustment screw does not foul on the cut-out wall. Fix into to place with screws as shown

## 5. Fit your door guides

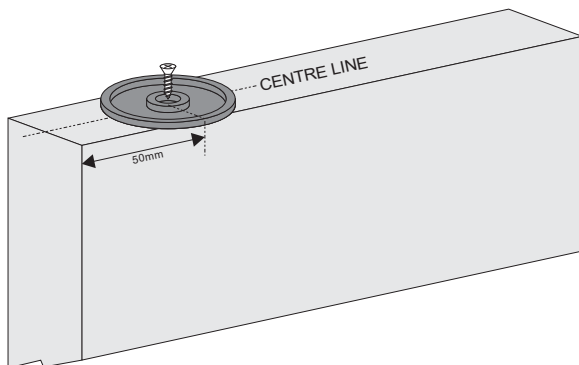

Fix your door guides to the top of your door, centred and 50mm in from each end, with screws as shown.

## 6. Fit your doors

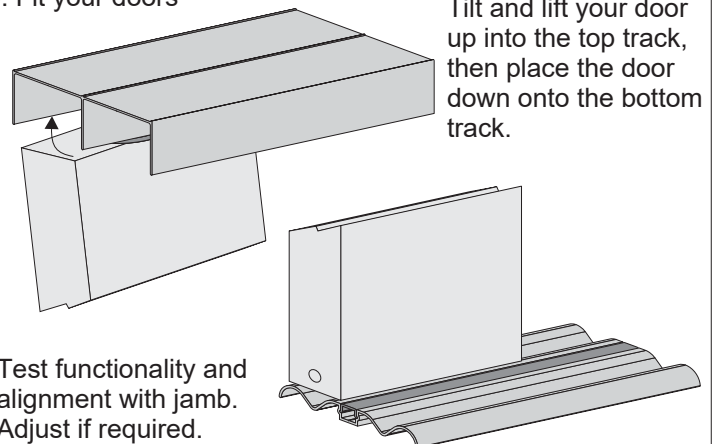







Test functionality and alignment with jamb. Adjust if required. Repeat for each door.

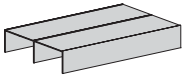
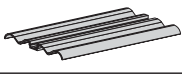

# ROBEMAKER

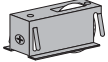
SLIDING WARDROBE DOOR TRACK SYSTEM - 50kg MAXIMUM DOOR LOAD

## PACK CONTENTS

Item Description	Available Colour	2 Door Kit 1620mm	3 Door Kit 2420mm	4 Door Kit 3240mm
Double Top Track 	Clear Anodised White	1 x 1620mm	1 x 2420mm	1 x 3240mm
Double Bottom Track 	Clear Anodised White	1 x 1620mm	1 x 2420mm	1 x 3240mm
Clip-down Cover Strip 	Charcoal	1 x 1620mm	1 x 2420mm	1 x 3240mm
Adjustable Roller 	Zinc	4	6	8
Nylon Door Guide 	Black	4	6	8
#6 x 19mm Pan Head Screw (for tracks and rollers) 	Zinc plated	13	18	26
#6 x 16mm CSK Screw (for door guides) 	Zinc plated	4	6	8

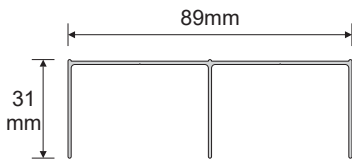

Top track

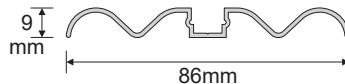

Bottom track

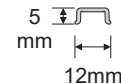

Cover strip

30mm min.  
40mm max.



Door width

### DOOR WIDTH CALCULATIONS: (Recommended overlap IS 20mm)

#### 2 DOOR OPENING

$$\text{DOOR WIDTH} = \frac{\text{OPENING WIDTH} + 20\text{mm}}{2}$$

$$\text{OPENING WIDTH} = (2 \times \text{DOOR WIDTH}) - (1 \times \text{OVERLAP})$$

E.G. (2 x 820mm) - (1 x 20mm) = 1620mm



#### 3 DOOR OPENING

$$\text{DOOR WIDTH} = \frac{\text{OPENING WIDTH} + 40\text{mm}}{3}$$

$$\text{OPENING WIDTH} = (3 \times \text{DOOR WIDTH}) - (2 \times \text{OVERLAP})$$

E.G. (3 x 820mm) - (2 x 20mm) = 2420mm

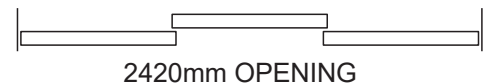

#### 4 DOOR OPENING

$$\text{DOOR WIDTH} = \frac{\text{OPENING WIDTH} + 40\text{mm}}{4}$$

$$\text{OPENING WIDTH} = (4 \times \text{DOOR WIDTH}) - (2 \times \text{OVERLAP})$$

E.G. (4 x 820mm) - (2 x 20mm) = 3240mm

